

OFFER FOR

Factory overhauled Buhrs 1000 system, certified with warranty

Issue date: 19-12-2019

OFFERING PARTY

Company: Buhrs BV
Contact person: Koos Buis
E-mail: KoosBuis@buhrs.com
Telephone: 00 31 (0)75 7990 600

SYSTEM INFORMATION

System brand: Buhrs
Machine type: Buhrs 1000 Poly & Paper Wrapping System
(max.13.000 c/h)
Machine number: 4451-669
Year: 2008
Availability: First come first serve basis
Condition: Good
Demo: To be discussed

CONFIGURATION

Pos.	Qty.	Description of item
1	1	Buhrs 1000 main product feeder, type shuttle feeder
2-3	1	Buhrs 1000 master base station
2a	1	Buhrs 1000 rotary feeder
3a	1	Buhrs HF4 friction feeder with adjustable interface for Buhrs Filmwrapping Systems - INCL VACUUM! 970 mm high (ordered with order 20406)
3b	1	Preparation of a Buhrs 1000 base for HF 4 feeder on 2 positions
4	1	Buhrs 1000 module for filmpackaging with double action sealbar, max 13.000
4a	1	Buhrs 1000 Register control unit
4b	1	60 mm kit for Buhrs 1000 wrapping module;
4c	1	Lower vacuum belt in wrapping module and upper vacuum in pulling belt.

This configuration can be changed depending on your application or requirements with new or used equipment.

Buhrs B.V.

Lay-out

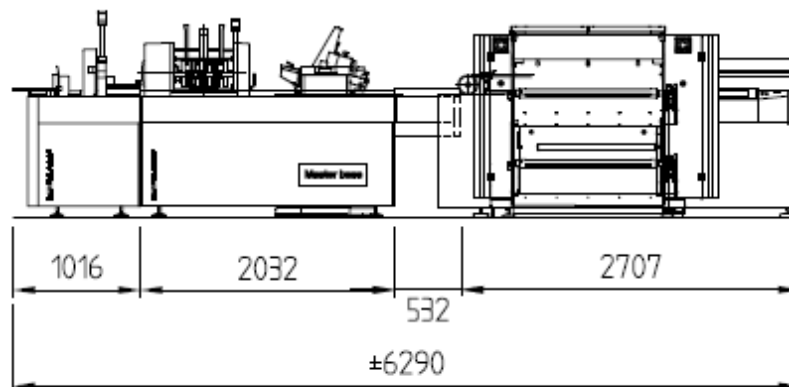
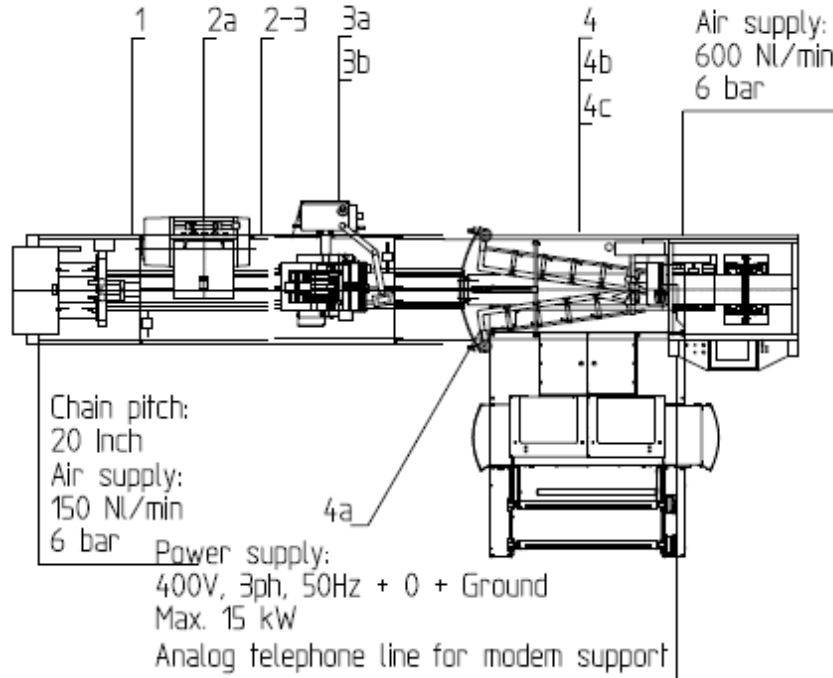

Buhrs B.V.

Vredeweg 7 • 1505 HH Zaandam • The Netherlands • T +31 (0) 75 7990600 • F +31 (0) 75 7990610 • E info@buhrs.com •
www.buhrs.com • VAT no. NL 8228.84.811.B.01 • Chamber of Commerce – nr. 50717529 • IBAN NL23 INGB0653659423 • BIC INGBNL2A