

Buhrs ST4

Compensating Stacker



Buhrs has developed a new servo driven, highly productive compensating stacker. This new **Buhrs ST4 stacker** is specifically designed for handling wrapped and non-wrapped products.

Buhrs ST4

The heart of the new **Buhrs ST4 stacker** is the so-called zero friction retaining system for which a patent has been applied for. The essence of the system is that the catching and passing unit doesn't impose friction forces on the product. This eliminates shifting and/or damaging of the product (stack). And, moreover, the movements can be faster, which increases the number of stacks per minute.

Main improvements

- Maximum product width expanded from 300 to 420 mm (420 mm square products are possible)
- 2nd level in product catch
- Minimum stack size down to 1 product
- Maximum number of stacks: 55 per minute
- Double-sided output possibilities: in-line (forward and backward) or square (right and left)
- Long infeed is possible as an option

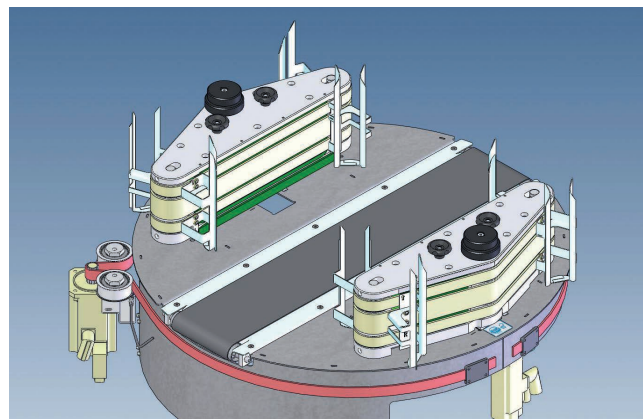

Options

- Long infeed arm to reduce infeed angle
- Water dispenser in infeed for more stable stacks
- Vacuum belt infeed for gimmicks and variable thickness

Key features

- Infeed belt at same speed as preceding system
- Single side support for easy belt maintenance
- Low drop height for stable stack forming
- Slow start servo outfeed to avoid deformation of the stack
- Designed to handle wrapped products
- Open, accessible design for jam removal and maintenance

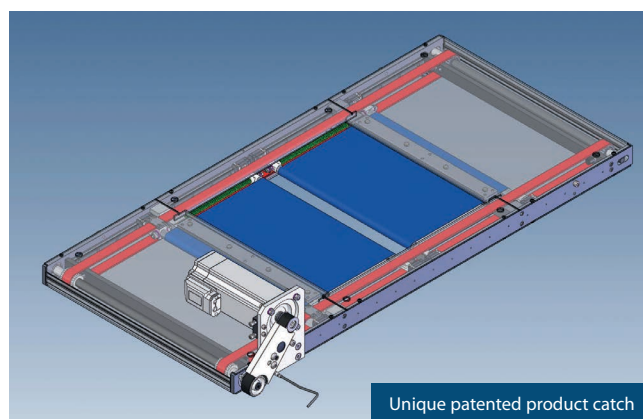

Unique patented product catch

Technical specifications

		Short infeed	Long infeed
• Dimensions of stacker	- Module length	2500 mm / 8.2'	3700 mm / 12.1'
	- Width	1000 mm / 3.2'	1000 mm / 3.2'
	- Height	11800 mm / 5.9'	1800 mm / 5.9'
	- Product input height	1020 to 1270 mm / 3.3' to 4.2'	770 to 1270 mm / 2.5V to 4.2'
• Dimensions of products	- Length (travel direction)	110 to 420 mm / 4.3" to 16.5"	
	- Width	55 to 420 mm / 6.1" to 16.5"	
	- Thickness	Maximum 80 mm / 3.1"*	
	- Stack height	Maximum 235 mm / 9.3"	
• Capacity	- Bundles per minute	55 (uncompensated)	
	- For bundle size 4 (all product sizes)	13,000 (pph) **	
	- For bundle size 6 (A4 and smaller)	19,000 (pph) **	
	- For bundle size 8 (A4)	21,000 (pph) **	
	- For bundle size 8 (A5)	26,000 (pph) **	

* Depending on product characteristics ** Maximum capacity at limited thickness

Specifications are subject to any change without notice Specifications are subject to change without notice.